

**PRS-7973**  
**Fault Recording &**  
**Ranging Equipment**  
**Manual**

**CYG SUNRI CO., LTD.**

V1. 0. 1

---

Before use of this product, please carefully read this chapter!

This chapter describes safety preventive recommendations to be observed before use of this product. For installation and use of this product, make sure to fully read and understand contents of this chapter.

Our company shall not be responsible for any harm due to neglect of relevant warning in this manual or improper operation.

Before any operation of this equipment, relevant discipline personnel must carefully read this manual and get familiar with relevant operation contents.

#### Operation guide and warnings

In this manual, the following indication markings and standard definitions will be used:



Danger!

Neglect of this safety preventive measure will cause personnel death, serious injury, or serious equipment damage.



Warning!

Neglect of this safety preventive measure may cause personnel death, serious injury, or serious equipment damage.



Attention!

Neglect of this safety preventive measure may cause slight personnel injury or equipment damage. This item is especially applicable to damage of this equipment and possible damage of protected equipment.



Warning!

To enhance or modify existing functions, both equipment hardware and software may be upgraded. Please confirm version of this manual compatible with your product.



Warning!

During operation of electrical equipment, some components may have high voltage. Incorrect operation may cause serious personnel injury or equipment damage.

Only qualified professionals are allowed to work on or near this equipment. Working personnel shall be familiar with precautions and work flows mentioned in this manual, as well as safety regulations.

Pay special attention to the requirement that some general purpose rules for work on HV live equipment must be followed; if not, serious personnel injury or equipment damage may occur.



- Exposed terminals

With the equipment live, never touch exposed terminals, as these may have dangerous high voltage.

- Residual voltage

After equipment power supply is turned off, there may still be dangerous voltage in DC circuits. Such voltage will only disappear after a few seconds.



- Earthing

Equipment earthing terminal must be reliably earthed.

- Operating environment

This equipment can only be run in an atmospheric environment of specified technical parameters not subject to abnormal vibration.

- Ratings

For connection to DC power supply circuit, please confirm its conformity with equipment rated parameters.

- Printed circuit boards

With the equipment live, never plug or unplug PCB; otherwise accidental fault may occur in the equipment.

- External circuits

To connect equipment output contact to an external circuit, make sure to carefully check external power supply voltage used, to prevent overheating of connected circuit.

Version:

P/N:

Copyright © 2019 CYG CYG SUNRI CO.,  
LTD

We have all intellectual property rights in this document and its contents unless specially authorized, and prohibit copying or distributing to third parties. Any infringement of intellectual property rights such as our company's version will be prosecuted by our company

We carefully review the contents of this document on a regular basis. There will be necessary corrections in subsequent versions but inevitably there will be some errors. Suggestions for improvement are welcome. We reserve the right to make technical improvements without prior no

Company address: No. 13, Keji Bei Yi Road,  
North District, High-tech Industrial Park,  
Nanshan District, Shenzhen

postcode:518057

Company website: [www.sznari.com](http://www.sznari.com)

To purchase products please contact:

call: 0755-33018888, fax: 0755-33018846

E-mail: [market@sznari.com](mailto:market@sznari.com).

Technical support, please contact:

call: 400-678-8099, fax: 0755-33018889

E-mail: [serve@sznari.com](mailto:serve@sznari.com).

---

---

<b>1. General</b> .....	<b>7</b>
1.1 Applicable scope.....	7
1.2 Features config.....	7
1.2.1 Main features.....	7
1.3 System structure.....	8
<b>2. Technical parameters and performance indices</b> .....	<b>8</b>
2.1 Rated parameters .....	8
2.2 Power consumption.....	9
2.3 Overload capacity .....	9
2.4 Insulation performance.....	9
2.5 Impulse voltage .....	10
2.6 Mechanical performance .....	10
2.7 Environmental conditions .....	10
2.8 Resistance to disturbance.....	11
2.9 Sampling indices .....	11
2.10 Recording capacity and storage.....	11
2.11 Date recording modes .....	11
2.12 External communication .....	12
2.13 GPS timing mode .....	13
<b>3. Hardware description</b> .....	<b>13</b>
3.1 Overview.....	13
3.2 Structure and installation.....	13
3.2.1 Device description.....	13
3.2.2 PRS-7973 Transmitter.....	20
3.3 Ground description .....	21
3.4 Grounding of cabinet.....	21
3.5 Device grounding terminal .....	23
<b>4. Description of functions and use of software</b> .....	<b>24</b>
4.1 Description of main functions .....	25
4.1.1 Main system interface .....	25
4.1.2 Real-time monitoring .....	27

---

4.1.3 Engineering configuration.....	28
4.1.4 Management of settings .....	38
4.1.5 Waveform analysis .....	42
<b>5. Power Quality Monitor.....</b>	<b>44</b>
5.1 Main function describe.....	44
<b>6. Commissioning.....</b>	<b>44</b>
6.1 General.....	44
6.2 Safety description .....	45
6.3 Inspection of equipment.....	45
6.3.1 Inspection power-on.....	45
<b>7. Maintenance. ....</b>	<b>47</b>
7.1 Arrangement of maintenance schedule .....	47
7.2 Tracking of faults and repair .....	47
7.3 Replacement of faulty card.....	47
7.4 Cleaning .....	48
7.5 Storage .....	48

# 1. General

## 1.1 Applicable scope

PRS-7973 fault recording and ranging equipment is used to record the whole process of change of electrical quantities such as current, voltage, frequency, and their derived quantities (active power and reactive power etc.) as well as relevant non-electrical quantities during various faults in the power system, e.g. short circuit, oscillation, frequency collapse, and voltage collapse etc.

PRS-7973 fault recording and ranging equipment adopts centralized design concept and allows flexible configuration according to engineering demands. It can serve both as fault recording and ranging equipment for power systems of various voltage levels and as unit fault recording and analysis equipment for power generation units of various capacities.

## 1.2 Features config

### 1.2.1 Main features

- ✧ **Flexible modular design:** Flexible modular design is adopted so that this equipment is easy and flexible to assemble, can adopt both centralized and distributed design, and has extremely high expandability.
- ✧ **High performance device type design:** This equipment adopts 19" standard chassis and card type rear plugging/unplugging structure, in which strong power and weak power are thoroughly separated. PCBs adopt multi-layer board and SMT process, greatly improving equipment reliability.
- ✧ **Relatively strong resistance to EM disturbance:** The EM disturbance resistance capability is designed according to requirements for relay protection and the fast transient performance meets class IV requirements.
- ✧ **Satisfaction of new standards and new user requirements:** This equipment can record both transient data according to complete internal independent startup criteria and long-term continuous stable state data as required. It can save complete large disturbance full process and stable state running data.
- ✧ **Flexible engineering configuration:** Hardware and software design of this equipment can adapt to applications of unit fault recording and line ranging fault recording. For engineering application, just carry out simple configuration operations as required. Engineering application is very easy and flexible.
- ✧ **Use of Linux operating system:** This equipment uses Linux operating system

and is protected against computer viruses, to allow safer and more reliable operation.

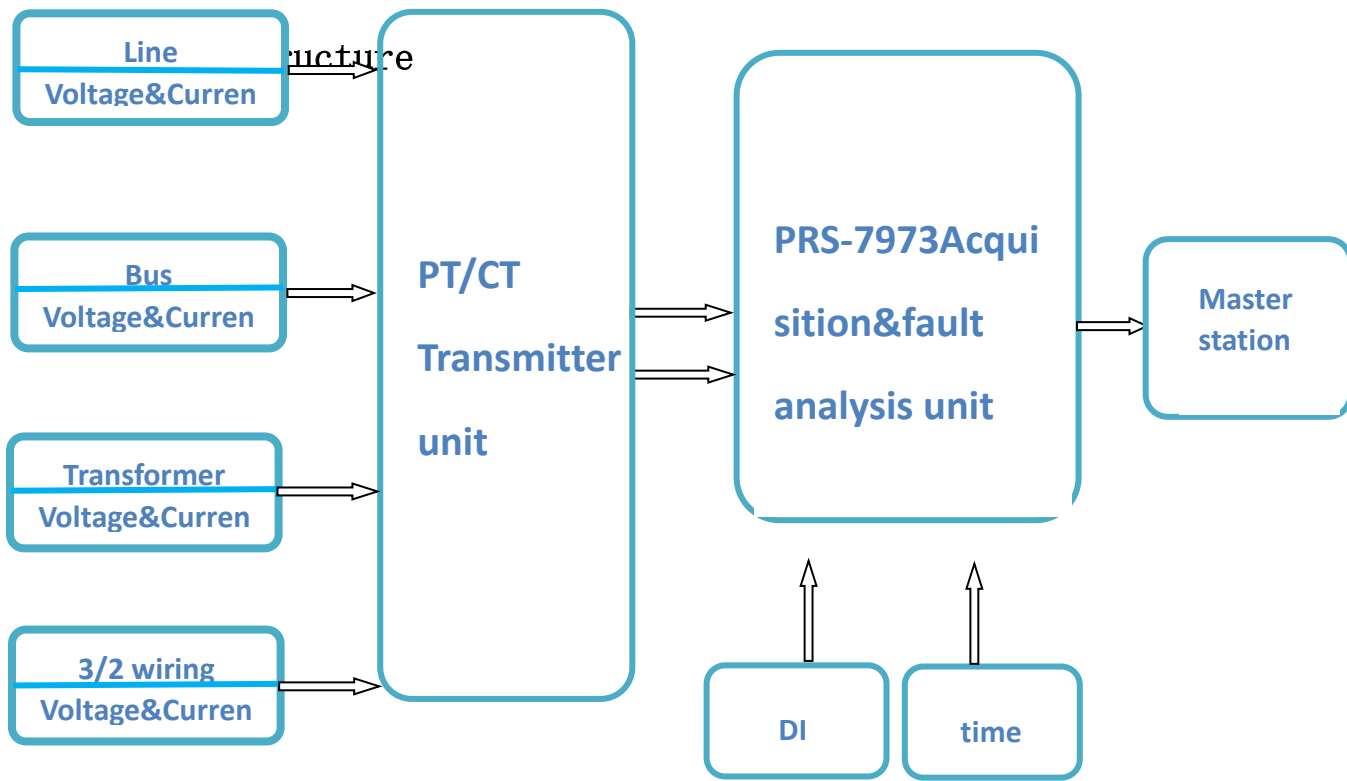

## 2. Technical parameters and performance indices

### 2.1 Rated parameters

Frequency FN: 50Hz;

AC current IN: 1A、5A;

AC voltage UN:  $100/\sqrt{3}$  V、100V;



## 2.2 Power consumption

Device	Power consumption
PRS-7973 fault recording & ranging analysis unit	<50W
PRS-7973 fault recording & ranging transmitters	<50W

## 2.3 Overload capacity

**AC current circuit:** 2 times rated current: continuous operation permitted;

10 times rated current: operation for 10S permitted;

40 times rated current: operation for 1S permitted

**AC voltage circuit:**

2 times rated voltage: continuous operation permitted

## 2.4 Insulation performance

Insulation resistance: under normal atmospheric conditions, insulation resistance between all circuits of this equipment and its housing is as shown in Table 1-1.

**Table 1-1 Specified values of circuit insulation**

Rated insulation voltage	Insulation resistance requirement
<63	≥10 (use 250V megger)
≥63	≥10 (use 500V megger)

Dielectric strength: Under standard testing atmospheric conditions, this equipment can withstand power frequency (50Hz) voltage for 1min without breakdown, flashover, or device damage. The testing voltage shall be selected according to Table 1-2. During the test, when voltage is applied on any tested circuit, other circuits shall be interconnected at equal potential and earthed.

**Table 2-2 Specified values of testing voltage**

Tested circuit	Rated insulation voltage	Testing voltage (V)
AC input circuit to earth	63~250	2000
DC power supply input circuit to	63~250	2000
BI circuit to earth	≤63	500
Signal and alarm output contact to	63~250	2000
Between circuits without electric connection	63~250	2000
	≤63	500

## 2.5 Impulse voltage

Under standard testing atmospheric conditions, 1.2/50μ standard lighting wave short impulse voltage shall be withstood between equipment DC power supply input circuit/AC input circuit/output contact circuit and earth, and between these circuits (open circuit testing voltage peak value is 5kV), without damage of equipment insulation.

## 2.6 Mechanical performance

**Working conditions:** This equipment can withstand severity class I shock response and impact response test.

**Transport conditions:** This equipment can withstand severity class I shock endurance, impact, and bump test.

## 2.7 Environmental conditions

**Working temperature:** -10℃~+55℃

**Storage temperature:** -25℃~+70℃; no irreversible change when no excitation quantity is applied; this equipment shall work normally after restoration of temperature.

**Atmospheric pressure:** 80kPa~110kPa

**Relative humidity:** Monthly mean maximum relative humidity of the wettest month is 90% and monthly mean minimum temperature of this month is 25℃ (without surface dewing). At highest temperature of 40℃, mean maximum relative humidity shall not exceed 50%.

## 2.8 Resistance to disturbance

**Fast transient disturbance test:** This equipment shall be able to withstand severity class IV fast transient disturbance test specified by 4.1 of GB/T 14598.10-1996.

**Static discharge test:** This equipment can withstand severity class IV static discharge test specified by 4.2 of GB/T 14598.14-1998.

**Pulse train disturbance test:** This equipment can withstand severity class III 1MHz and 100 kHz pulse train disturbance test specified by 3.1.1 of GB/T 14598.13-1998.

**Radio frequency EM field radiation immunity test:** This equipment can withstand severity class III RF EM field radiation immunity test specified by 4.1.1 of GB/T14598.9-2002.

## 2.9 Sampling indices

**A/D conversion precision:** 16 bits

**Sampling rate:** 12800Hz (highest; can be flexibly configured according to different time periods)

**Binary quantity resolution:** 0.5ms

**Frequency resolution:** 0.01Hz

**Harmonic wave resolution:** 31<sup>st</sup> order (when input signal exceeds 20% rated value)

**Ranging precision:**  $\leq 2\%$

## 2.10 Recording capacity and storage

Single fault file capacity reaches 20M so that one such file can record complete fault data waveform before and after a fault. This equipment is complete with storage media of large capacity hard disks and electronic disks, which can store 3000 transient state fault files and 2500 stable state fault files. Fault data files can be uploaded to central analysis station or dispatch center via network, to allow users to query and print the same at any time. This equipment provides data of standard COMTRADE format specified by IEC 60255-24:2001, to facilitate data exchange with other fault analysis equipment.

## 2.11 Date recording modes

**Classification of data records:** Data recording modes of this equipment include recording of stable state data and recording of transient state data. Data files generated by these two types of recording can be named and saved respectively, and can be analyzed by equipment analysis software. Both stable state data and transient state

data have absolute time mark.

**Recording of stable state data:** According to demands, this equipment can continuously record important electrical quantities such as voltages, currents, and frequencies for comprehensive analysis. Activation of recording of stable state data can be set, as well as time of recording. Storage of stable state data files allows convenient search and remote call of such data.

**Transient state data recording mode:** In case of large disturbance in a power generation unit or the grid, this equipment will start automatically and enter transient state recording process. Recording will adopt the following mode.

**A-B time period:** Status data before start of large disturbance; original recorded waveform and effective values are output. Recording time can be set and shall be not less than 0.1s. Sampling rate can be set and shall be not less than 12.8k points/s.

**B-C time period:** Early stage status data after large disturbance; original recorded waveform and effective values are output at high speed. Recording time can be set and shall be not less than 0.1s. Sampling rate can be set and shall be not less than 12.8k points/s.

**C-D time period:** System dynamic process data; original recorded waveforms and effective values are output at low speed. Recording time can be set and shall be not less than 1s. Sampling rate can be set and shall be not less than 3.2k points/s.

**Activation conditions for recording of transient state data:** First start: automatic start when any starting condition set in advance is satisfied, and executed in the sequence of time periods A-B, B-C, and C-D.

**Conditions for restart:** During the process of recording activated earlier, if new automatic startup condition is satisfied, e.g. in time period C-D, recording will start again in time periods A-B, B-C, and C-D.

**Automatic termination conditions for recording of transient state data:** When recording in C-D time period is complete and no new automatic starting condition is satisfied, recording of transient state data will automatically stop.

Upon completion of recording of time period C-D, if no new automatic starting condition is satisfied, but the condition that activated this recording remains, time periods of A-B, B-C, and C-D will be entered again for next data recording. After restoration of external operating conditions to normal, activation will stop.

## 2.12 External communication

Three Ethernet interfaces (10Mbps, 100Mbps, 1000Mbps self-adaptive) and IEC-61850-MMS protocol are provided, allowing flexible connection to other supervisory control system of information management system.

## 2. 13 GPS timing mode

PRS-7973 fault recording and ranging unit provides one line of TTL interface, supports IRIG-B code timing, and performs calibration of clock of other units at the same time.

IRIG-B (TTL)	< 1us
Time service precision after 24 hours	250us

## 3. Hardware description

### 3.1 Overview

The standard configuration of the device is: a power system dynamic recording device, a collection transmitter unit.

### 3.2 Structure and installation

#### 3.2.1 Device description

PRS-7973 The power system dynamic recording device faces up to the following figure 3-1:



Figure 3-1 Power system dynamic recording device face-up diagram

Industrial - grade reinforced 6U full - wide standard chassis.  
Fully enclosed cabinet , rear wiring , embedded mounted on cabinet , back plate as shown in Fig . 3 - 2:

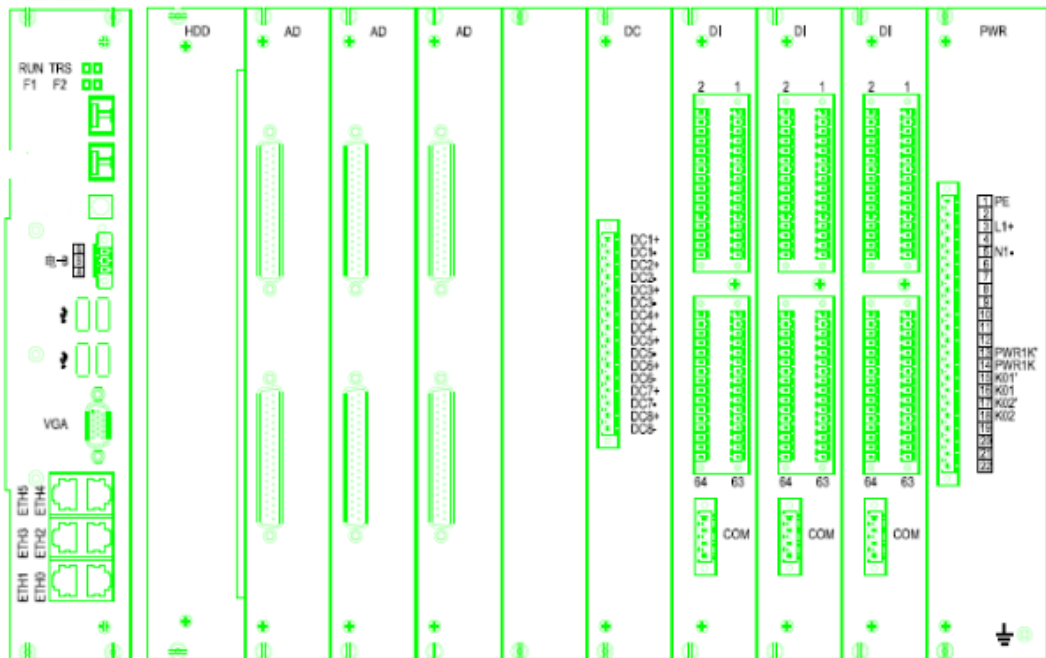

Figure3-2Back board diagram of the power system dynamic recording device  
CPU board has the following interface

VGA interface

B code timing interface (TTL)

USB interface

100Mbps Ethernet interface

The acquisition board has the following interfaces

DI board, passive node, drive voltage of DC110V; maximum 24 lines of BI quantities can be connected to one such board; largest configuration includes 8 DI boards (192 lines of BI quantities).

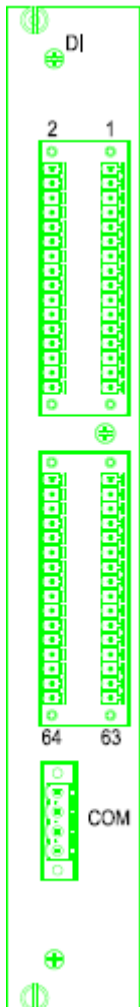

Terminal No.	Description
1~13	DC+
14~24	DC+
25, 26	DC-

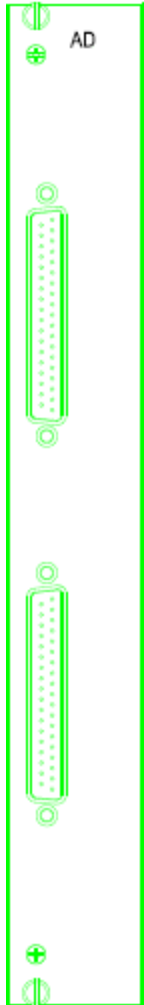

AD boards: receive small AC signals (AC current/voltage) uploaded by fault recording and ranging transmitter. Each DB37 interface can connect 16 lines of AC sampling and each AD board can connect 32 lines of AC sampling. At most 3 AD boards can be configured (connecting 96 lines of AC sampling data).





A DC board is connected with a maximum of 8 direct flow and can be extended to 16.

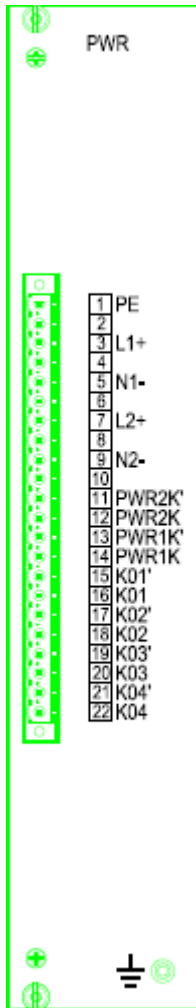

Terminal No.	Description
1	PE: earthing terminal
2	Idle terminal
3	L1+
4	Idle terminal
5	N1-
6	Idle terminal
7	L2+
8	Idle terminal
9	N2-
11、 12	Equipment power 2 supply loss alarm
13、 14	Equipment power 1 supply loss alarm
15、 16	Fault recording activation signal BO
17、 18	Equipment fault signal BO
19、 20	Alarm signal BO
21、 22	reserved

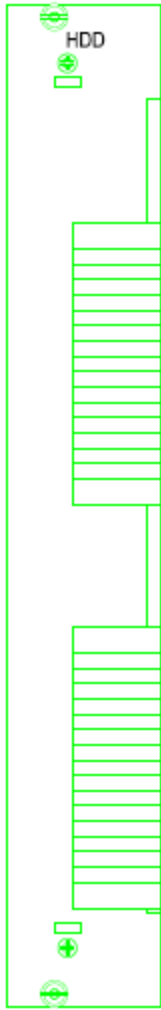

Hard disk board, equipped with 2 T level data hard disk.

### 3.2.2 PRS-7973 Transmitter

PRS-7973 transmitter faces up as shown in Figure 3-3 below



Figure 3-3 Image of Transmitter

 Attention:

Adequate space must be left up and down in the opening position of the screen cabinet or switchgear for heat dissipation.

All the hardware modules of the device must be properly and tightly inserted into the corresponding slot position on the device .

### **3.3 Ground description**

The device or circuit at the electrical installation induces the interference current in the electromagnetic interference. All these may interfere with the normal operation of electronic devices.

On the other hand, the running electronic can emit electromagnetic fields that may affect the normal operation of other electronic devices.

In order to minimize these effects, some standards for grounding.

### **3.4 Grounding of cabinet**

The cabinet must be designed to minimize the minimum impedance on the ground path from the electronics to the ground terminal of the cabinet .

For example , metal accessories such as side baffle and air baffle must be reliably connected to the grounding

horizontal bar of the screen cabinet face to face to ensure the small impedance path of ground impedance of RF interference. The contact surfaces of these metal plates must be well conductive and corrosion resistant.



Attention:

If the above conditions can not be satisfied, it is possible to form a resonant circuit at a certain frequency in a part of the screen cabinet or screen cabinet, which can amplify the transmission ability of interference and reduce the immunity to inductive interference at the same time.

The movable parts (such as front and rear doors) of the screen cabinet must be reliably connected to the grounding bar of the screen cabinet through flat copper strands. Screen cabinet frame and grounding bar must have reliable.

### 3.5 Device grounding terminal

The device has a grounding terminal on the AC module (AC) of the rear panel , which can be grounded by flat copper strands .When grounding , make the grounding with flat copper strands as short as possible .The device can only be grounded a bit , and connecting the ground terminals from the device to the device is not allowed .

The ground terminal and the AC enclosure metal housing are connected when reliably and tightly inserted into the device enclosure .Some other terminal rows of the unit also have ground marks , all of which are connected to the unit chassis inside the unit .Thus , the entire device needs only to be grounded by the ground terminal on the AC module (AC).

 Attention:

The rated voltage of the input power supply is 220 V and 110 V adaptive. Other voltage levels need special orders. Please check that the rated input voltage of the power supply module is the same as the control power supply voltage.

 Attention:

The power module provides 1# terminals and earthing posts for device grounding. The 1# terminal should be connected to the grounding column and then connected to the grounding copper bar of the screen cabinet through a special ground wire.

 Attention:

Good grounding is the most important measure against electromagnetic interference , so ensure the device good grounding before the device is put into use .

#### **4. Description of functions and use of software**



This chapter describes main functions of this equipment and relevant operation methods.

#### **4.1 Description of main functions**

From the point of view of operation, maintenance, and operation, the management analysis software of this equipment has the following six categories of functions:

- ✧ Real-time monitoring: real-time viewing of real-time operating quantity or status of data connected to the fault recording and ranging equipment, e.g. various analog quantities, binary quantities, equipment status quantities, and frequency etc.
- ✧ Management of fault files: classified management (inquiry, sorting, and retrieval etc.) of recorded fault files according to conditions of time, faulty equipment, and fault type etc.
- ✧ Waveform analysis: single item analysis, comprehensive analysis, and printing etc. of recorded fault files
- ✧ Settings management: enable, disable, modify, query, and print various fault recording settings
- ✧ Engineering configuration: initial configuration of connected binary quantity channels and analog quantity channels, and connected equipment channels (generator, transformer, line etc.) according to particular engineering requirements (note that since upon ex-factory, the configuration has been made according to agreement requirements and actual wiring, do not operate at will if not necessary)
- ✧ User management: allocation and management of users, user authorities, and user passwords

##### **4.1.1 Main system interface**

Main interface of PRS-7973 fault recording and ranging equipment is shown in Fig.4-1.

Communication status zone

Functional interface switching button zone

System run status

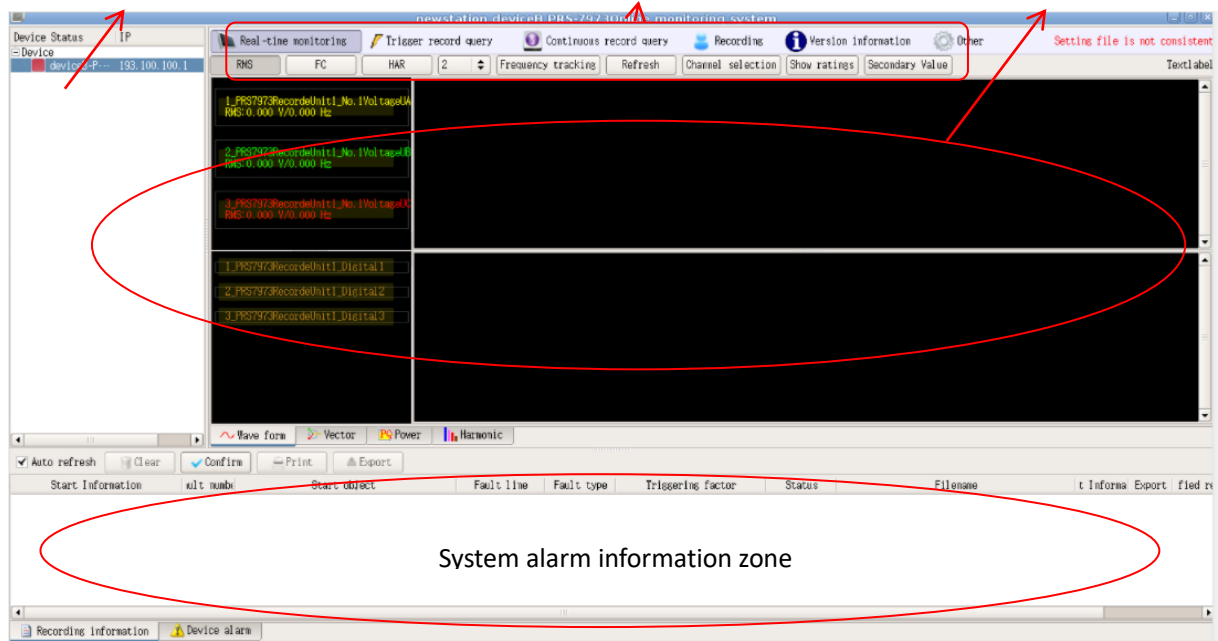

**Fig.4-1 Main interface of fault recording and ranging equipment**

1) Communication status zone:

- Device Status

There is a red square icon above “Device”, when recording analysis unit is not connecting with recording management. Otherwise, it shows a green square icon. Besides icon, it represents names of recording analysis unit.

- IP

It's a internal communication parameter in recording analysis unit.

2) Functional interface switching button zone

Real-time monitoring: display waveform and real-time power of current configured channel

Trigger record query: search transient record files.

Continuous record query: search continuous record files.

Recording: to handle record

Version information: it can indicate version of software including real-time monitor, the module of record management, MMS some drivers and FPGA.

Others: it mainly used to debug equipment by some alarm information.

3) System running indicators zone

Time calibration: indication of loss of IRIG-B clock source alarm; red upon alarm and green otherwise

Fault recording: indication of alarm for activation of equipment fault recording; red upon alarm and green otherwise

Self-check: indication of alarm for abnormality in equipment proper; red upon alarm and green otherwise

#### 4) System alarm information zone

Start-up information: only effective when the fault recording function configured for the system is enabled; fault recording activation time, fault type, and fault data are displayed;

Equipment alarm: alarm information upon abnormality of CPU, hardware, memory, or application software etc.

#### 5) Manual operation zone

Time calibration: after loss of system clock source, download time of management computer to real-time analysis device; normally used for testing

Reset: in case a red indicator on interface or device is lit, click this button to reset alarm message.

Manual fault recording: only effective when this equipment is configured as fault recorder; press this button to activate fault recording; normally used for testing

### 4.1.2 Real-time monitoring

The real-time data functional page includes four sub-pages:

#### 4.1.2.1 Real-time fault recording waveform page

The real-time fault recording waveform page displays real-time waveforms of analog and binary data. According to user demand, effective values (primary values and secondary values), first harmonic, and other harmonics (2<sup>nd</sup> to 31<sup>st</sup> harmonic waveforms) can be displayed. Refer to Fig.4-3.

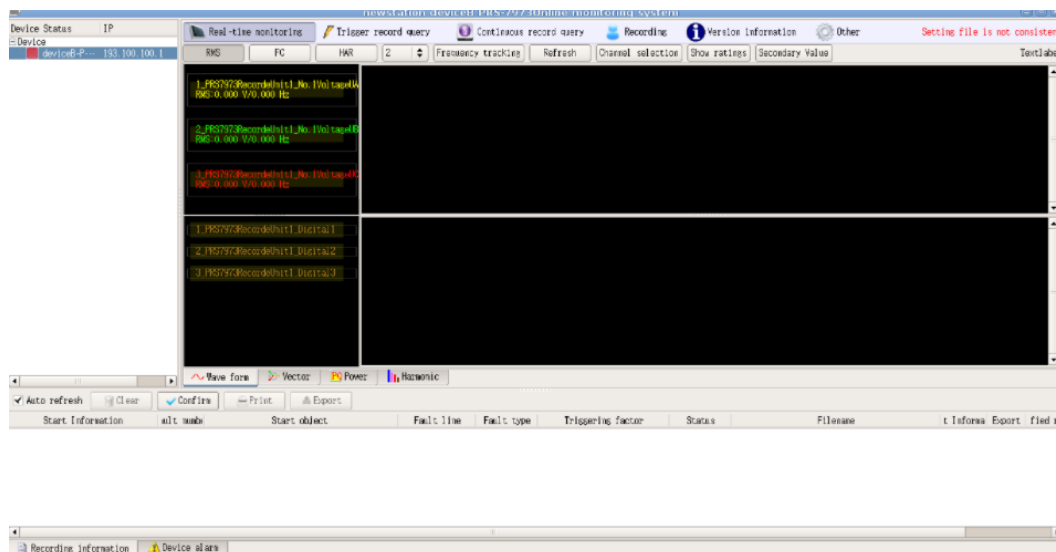

Fig.4-3

Through channel sieving function, real-time waveforms and statuses of data of major concern can be displayed according to primary equipment or any selected channel; refer to Fig.4-4.

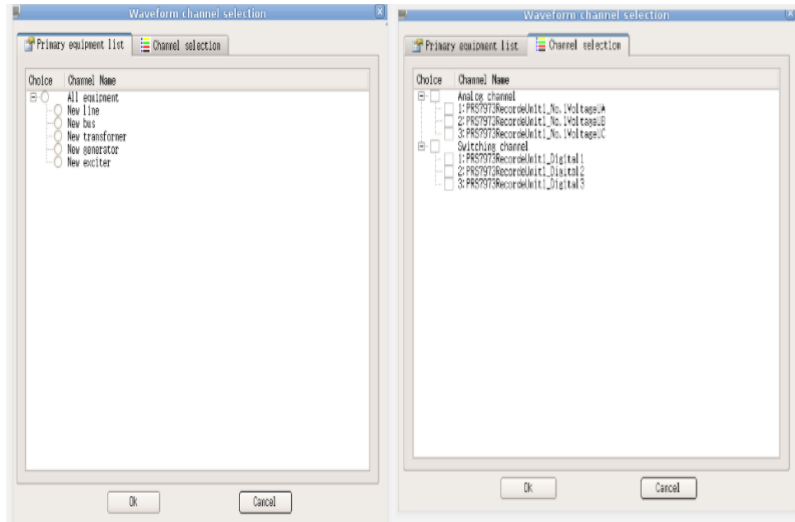

Fig.4-4

4.1.2.2 Real-time power page

The real-time power page displays power information of selected channel. Refer to Fig.4-5.

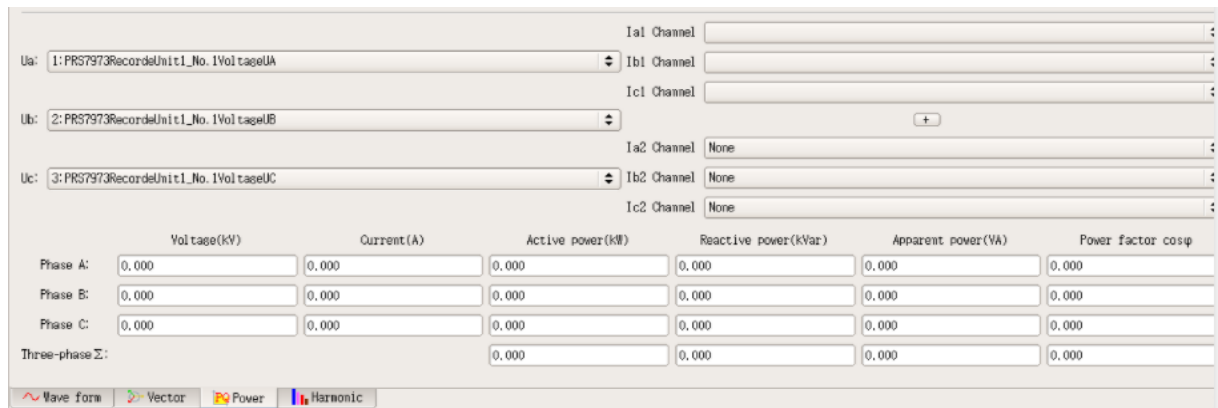

Fig.4-5

4.1.2.3 Vector

It displays real-time each phase angle of voltage and current. Usually used for debugging.

4.1.2.4 Harmonic

It can display DC, fundamental and 2<sup>nd</sup> to 31<sup>st</sup> harmonic component of each phase voltage or current by “channel selection” button.

4.1.3 Engineering configuration

According to particular engineering requirements, carry out initial configuration of connected analog quantity channels and connected equipment such as generator, transformer, and line. Note: Upon equipment ex-factory, configuration has been made according to panel wiring and agreement requirements; do not operate at will if not necessary. A complete engineering configuration includes 4 parts: “equipment parameters configuration”, “analog quantities configuration”, “binary quantities configuration”, and “primary equipment configuration”. First carry out “equipment parameters configuration”, then “analog quantities configuration” and “binary quantities configuration”, and finally “primary equipment configuration”. Default log-in password for the configuration tool is 666666.

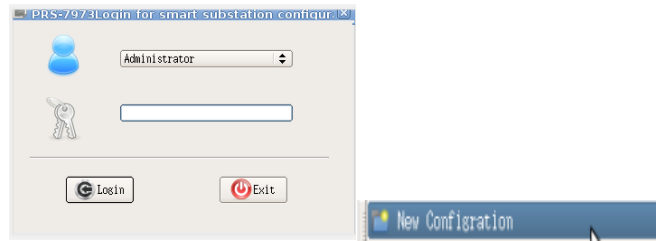

#### 4.1.3.1 Equipment parameters configuration

For new ex-factory equipment, when the configuration tool is opened for the first time, default configuration will be loaded. Engineering personnel need to modify relevant configuration according to actual engineering demands or the option (New Configuration File) in menu  (File) can be used to create new configuration.

Steps to create new configuration: First step: click button  (Import SCD) and select template file under the default directory. Second step: configure relevant information of substation; refer to Fig.4-6.

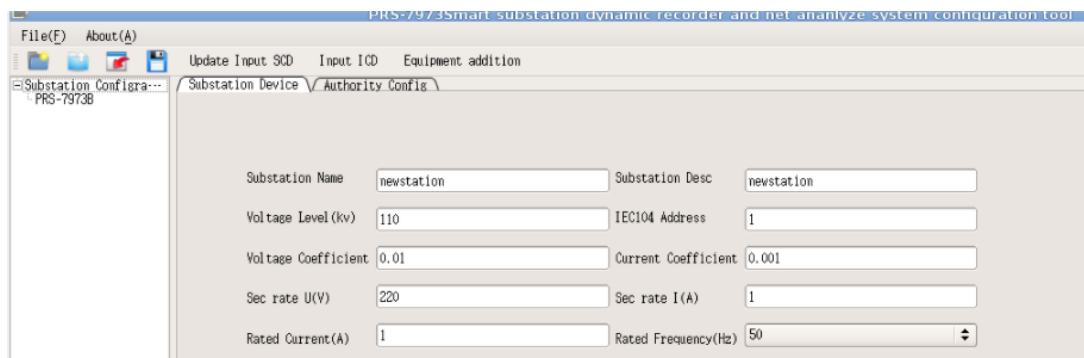
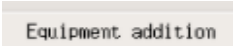

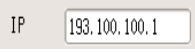
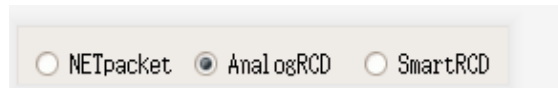

Fig.4-6

Step 3: click button  (Add Equipment), and add fault recording and ranging equipment for equipment parameters configuration. Use default equipment name . Use  (Manage IP) to configure IP of

fault recording analysis unit: normally use default IP of 193.100.100.1, which needs not be changed. For  (Equipment Description), name the equipment according to actual condition, and default name can be used if not required otherwise. Use Select Template functions to select corresponding template file (select  (Select Template).

Step 4: Select equipment function; please select Analog Fault Recording (refer to Fig.4-7).



**Fig.4-7**

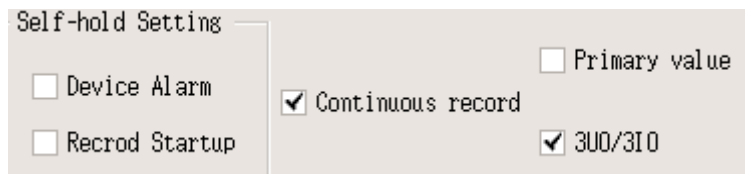

**Fig.4-8**

Step 5: According to actual demands, configure Equipment Alarm Self-hold, Fault Recording Start-up Self-hold, and Stable State Message Storage. After checking a self-hold function, alarm signals can only be reset using button  (Reset) in main online running interface or remote signal. If no self-hold function is checked, relevant alarms will be automatically reset after the signal disappears. Refer to Fig.4-8

Step 6: In the equipment configuration tab, configure source type as analog unit (Fig.4-9). Equipment parameters configuration is complete at this point.

Device Config				
<input type="button" value="Module Add"/>		<input type="button" value="Module Delet"/>		
	Datasource Description	Type	Address	Port
1	msgonline and record unit1	Analogue Unit	0	1

**Fig.4-9**

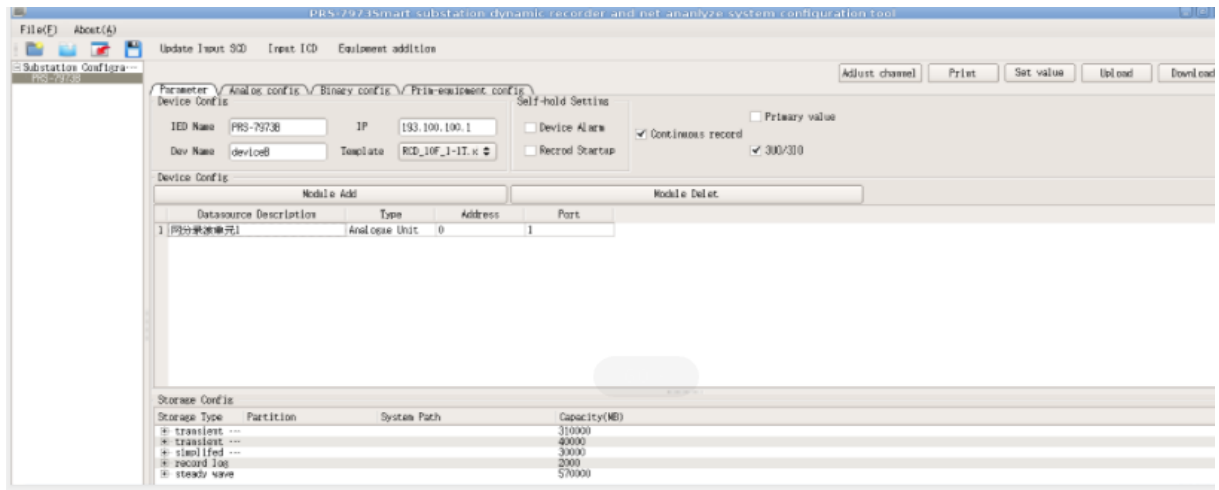

Fig.4-10 Equipment information configuration diagram

### 4.1.3.2 Analog quantities configuration

In default configuration, 96 lines of AC analog quantities and 8 lines of DC quantities have been configured. Engineering personnel shall modify channel names, channel marks, phases, channel types, primary ratings, secondary ratings, orders of magnitude, and units according to actual site demands. For new configuration, first select connected channels according to actual site demands and then modify relevant channel data. Modification of all items supports batch modification mode. After selecting relevant channel, use button Modify in the right key menu to modify relevant items. Refer to Fig.4-11.

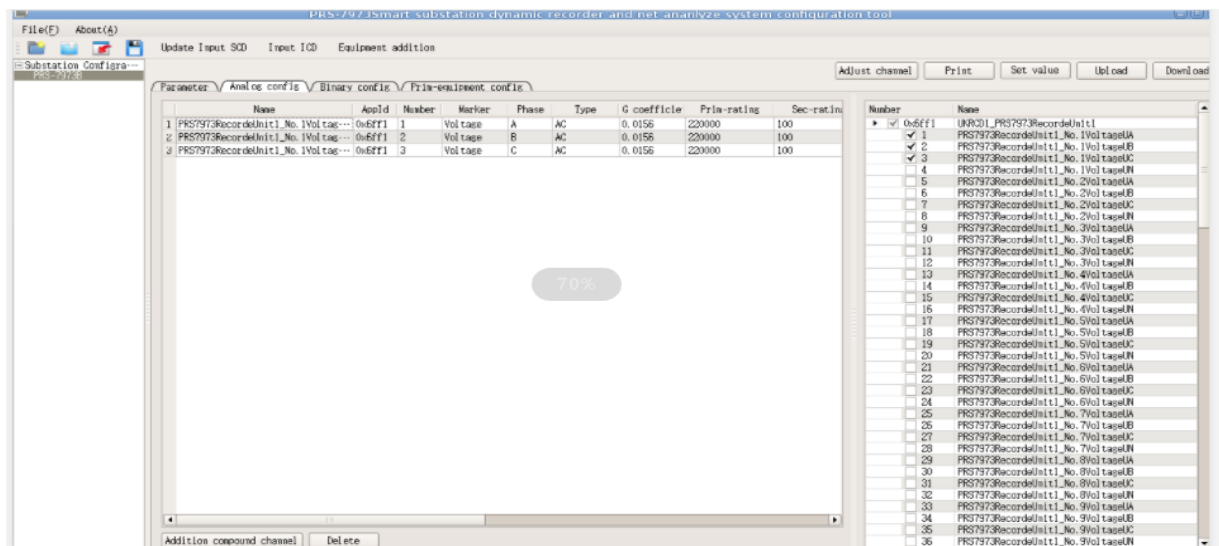

Fig.4-11

### 4.1.3.3 Binary quantities configuration

In default configuration, 192 lines of binary quantity channels have been configured. Engineering personnel shall modify channel names, channel types, channel marks, and contact types according to actual site demands. For new configuration, first select

corresponding binary quantity channels according to actual site demands, and then modify relevant channel data. Modification of all items supports batch modification mode. After selecting relevant channel, use button Modify in the right key menu to modify relevant items. Refer to Fig.4-12.

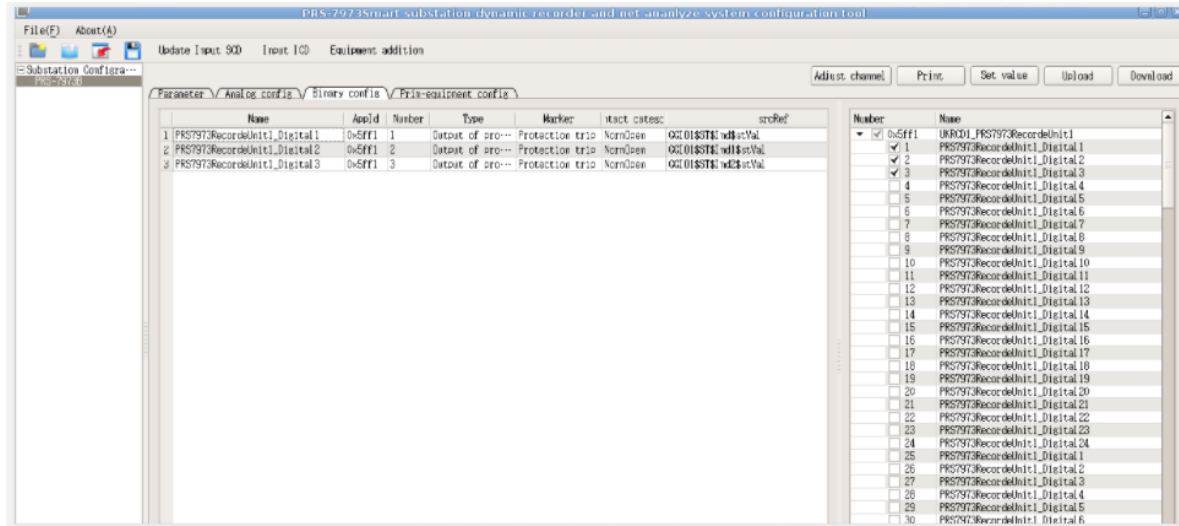

Fig.4-12

When channel type is configured as protection operation output and signals of circuit breaker position and switch position are triggered, fault will be judged in this activation of fault recording, and fault type will be determined according to internal logic, e.g. single phase earthing or 3-phase earthing etc. Refer to Fig.4-13.

	Name	Appld	Number	Type	Marker	Contact category	srcId
1	PRS7973RecordUnit1_Digital1	0x5ff1	1	Protection action output	Protection tripping	Normally open	GGI01\$ST\$I nd\$stVal
2	PRS7973RecordUnit1_Digital2	0x5ff1	2	Breaker position	NO-phase breaker close pos...	Normally open	GGI01\$ST\$I nd1\$stVal
3	PRS7973RecordUnit1_Digital3	0x5ff1	3	Switch position	General switch quantity	Normally close	GGI01\$ST\$I nd2\$stVal

Fig.4-13

#### 4.1.3.4 Primary equipment configuration

Engineering personnel shall configure information related to primary equipment according to actual site demands. First, select a new substation and configure relevant information of this substation at the right side. Here, just configure name of the substation, as shown in Fig.4-14.



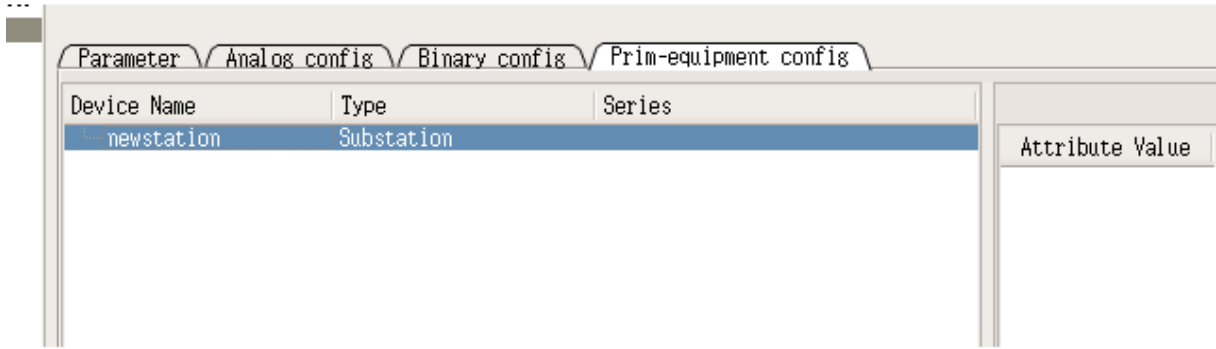

Fig.4-14

Select the substation and then use right key menu to add primary equipment, e.g. line, bus, transformer, generator, exciter etc. (Fig.4-15)

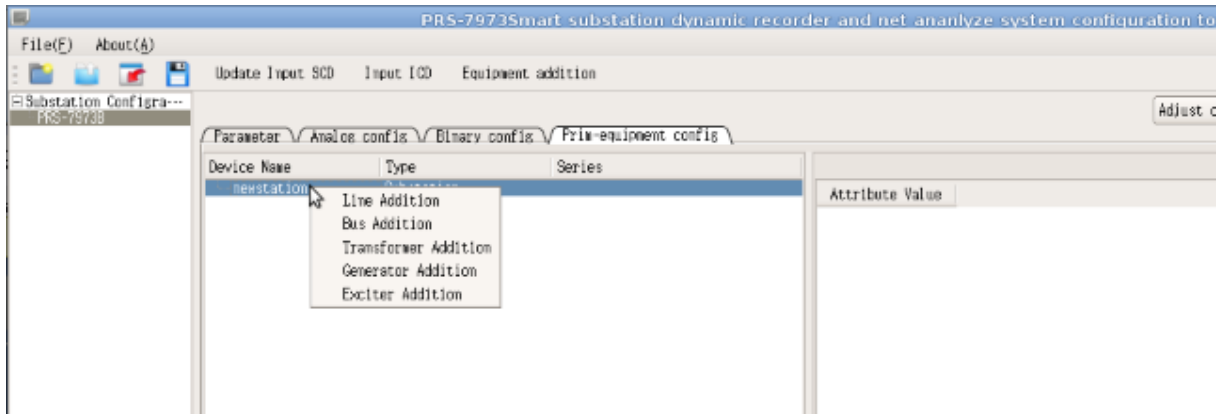

Fig.4-15

Create a bus: according to actual site conditions, select equipment status (enabled/disabled) and modify bus name, rated voltage, auxiliary side rated voltage, and TV installation position. This TV installation position can be line side or bus side. Bus parameters are shown in Fig.4-16.

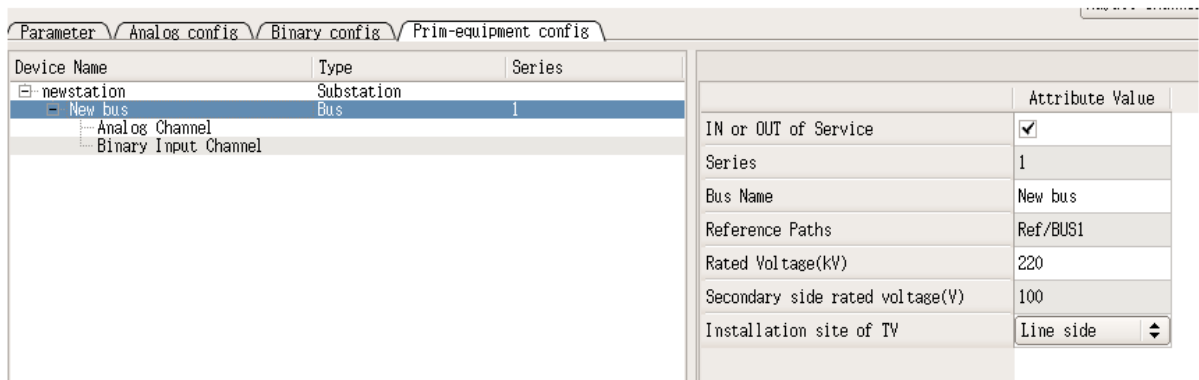

Fig.4-16

Associate analog and binary quantity channels corresponding to this bus and drag selected channels to relevant channel configuration box as per actual condition; batch

dragging is supported (Fig.4-17).

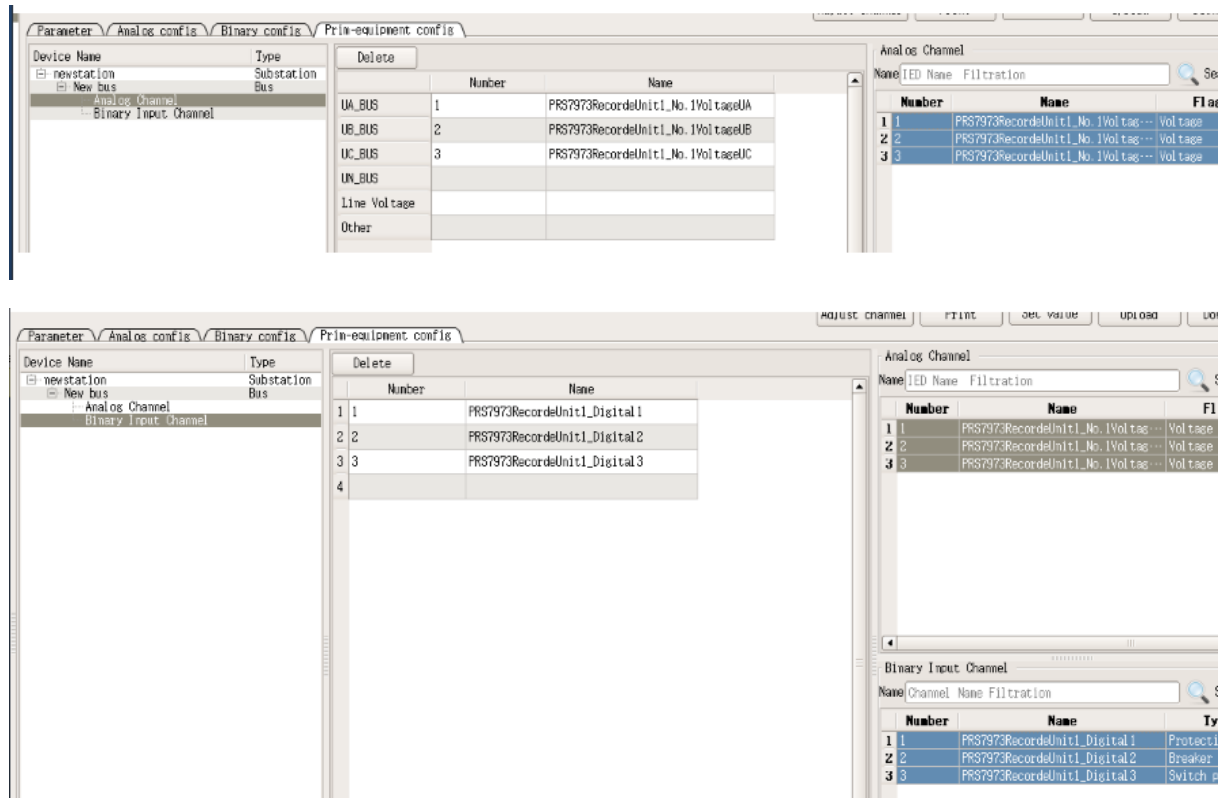
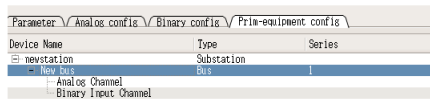

Fig.4-17

Create a line: select (by checking) equipment status (enabled/disabled), and modify line name, relevant bus ID (bus ID is established bus serial No. in



), rated voltage, rated current, and auxiliary side rated current according to actual site conditions. In case ranging function is required, the following shall be configured: line length, positive sequence resistance, positive sequence reactance, zero sequence resistance, zero sequence reactance, positive sequence capacitance, zero sequence capacitance, positive sequence conductance, zero sequence conductance, zero sequence mutual inductance resistance, and mutual inductance reactance. Particular items and data required for ranging shall be provided by upper dispatch entity. Besides, index No. (which is line serial No., same as bus ID), number of current branches, and direction of branch 1 current of the other group of lines of mutual transformer dual circuits shall be configured according to actual conditions. Refer to Fig.4-18.

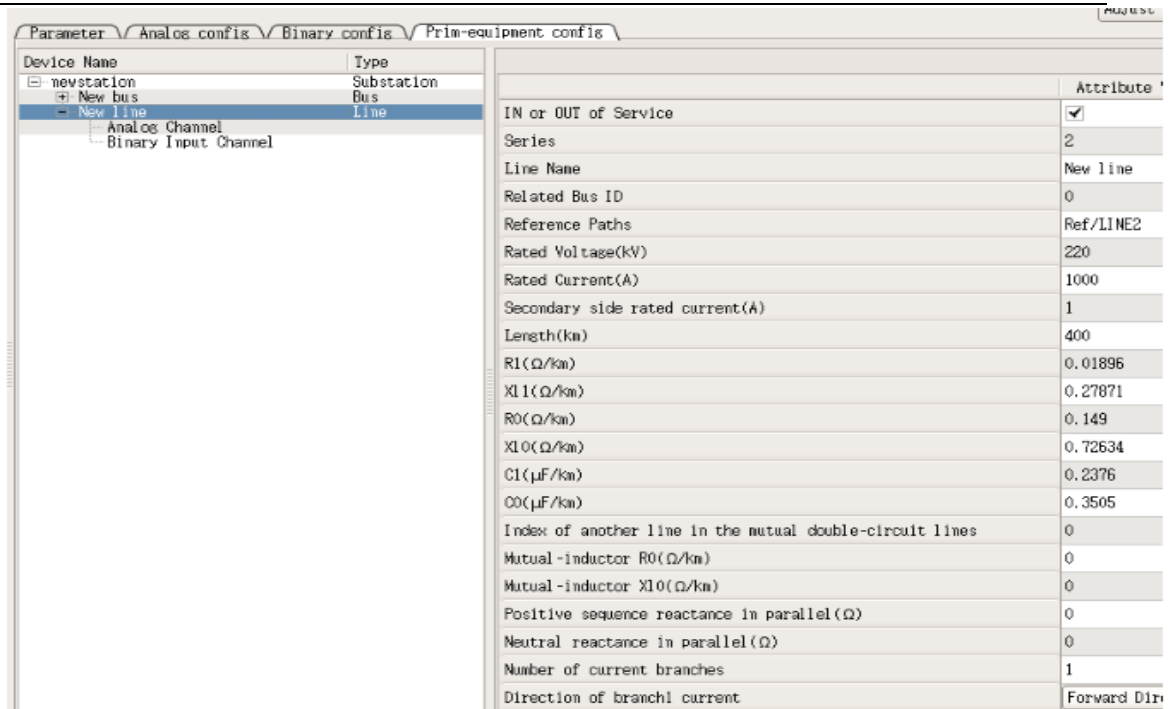

Fig.4-18

Configuration mode for line related analog quantity channels and binary quantity channels is the same as for bus.

Create a transformer: first select number of transformer windings, e.g. 2-winding transformer or 3-winding transformer. Refer to Fig.4-19.

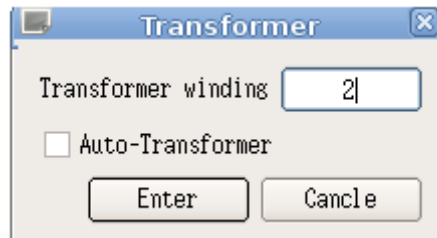

Fig.4-19

Configure transformer status (enabled/disabled), transformer name, and transformer rated capacity, e.g. in Fig.4-20.

Attribute	Value
IN or OUT of Service	<input checked="" type="checkbox"/>
Series	3
Transformer Name	New transformer
Reference Paths	Ref/TRANSFORMER3
Rated transformer capacity(MVA)	300
Transformer winding branches	2

**Fig.4-20**

Configure information at each side of the transformer. Take 2-winding transformer as an example, refer to Fig.4-21.

	Attribute Value
Reference	Ref/WIND
Rated Voltage(kV)	220
Rated Current(A)	1000
Wiring Group	yn0
Branches of winding current	1
Direction of branch1 current	Forward Direct

	Attribute Value
Reference	Ref/WIND
Rated Voltage(kV)	35
Rated Current(A)	2000
Wiring Group	d11
Branches of winding current	1
Direction of branch1 current	Forward Direct

**Fig.4-21**

Configure transformer related analog quantity channels and binary quantity channels; use the same method as for bus.

Create a transformer and configure the following information according to actual site demands; refer to Fig.4-22.

Device Name	Type
newstation	Substation
+ New bus	Bus
+ New line	Line
+ New transformer	Transformer
- New generator	Generator
- Analog Channel	
- Binary Input Channel	

	Attribute Value
Series	4
Generator Name	New generator
Reference Paths	Ref/GENERATOR4
Related Transformer ID	0
Generator Type	Steam turbine
Rated Frequency	50
Rated Capacity	60
Power factor	0.9
Rated Primary Voltage	10
Rated Current Of Rotor	100
Secondary Rating Of Rotor Shunt	10
Excitation Mode	Excitation tra
Current direction for generator terminal	Flow out of ge
Longitudinal synchronous reactance	0.26
Quadrature axis synchronous reactance	0.26
Transient longitudinal synchronous reactance	0.025
Interconnection Xl	1
Neutral current direction	Forward Direct
Branch groups for generator neutral point	1
Current direction of neutral branch 1	Forward Direct

**Fig.4-22**

Create an exciter and configure the following information according to actual site demands; refer to Fig.4-23.

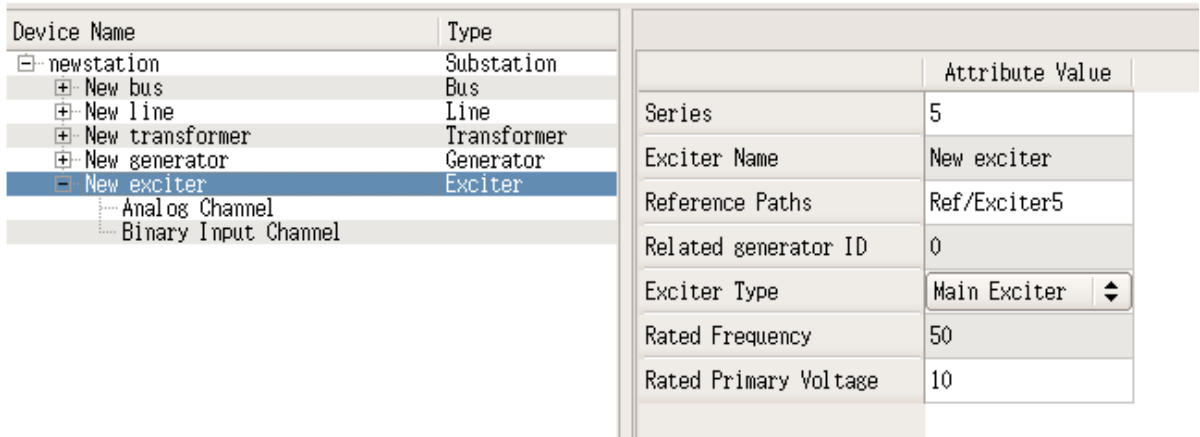
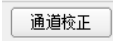

Fig.4-23

#### 4.1.3.5 Channel calibration

In case of relatively large analog quantity numerical deviation at site, click button

 (Calibrate Channel) to calibrate the channel again. Channel calibration page is shown in Fig.4-24.

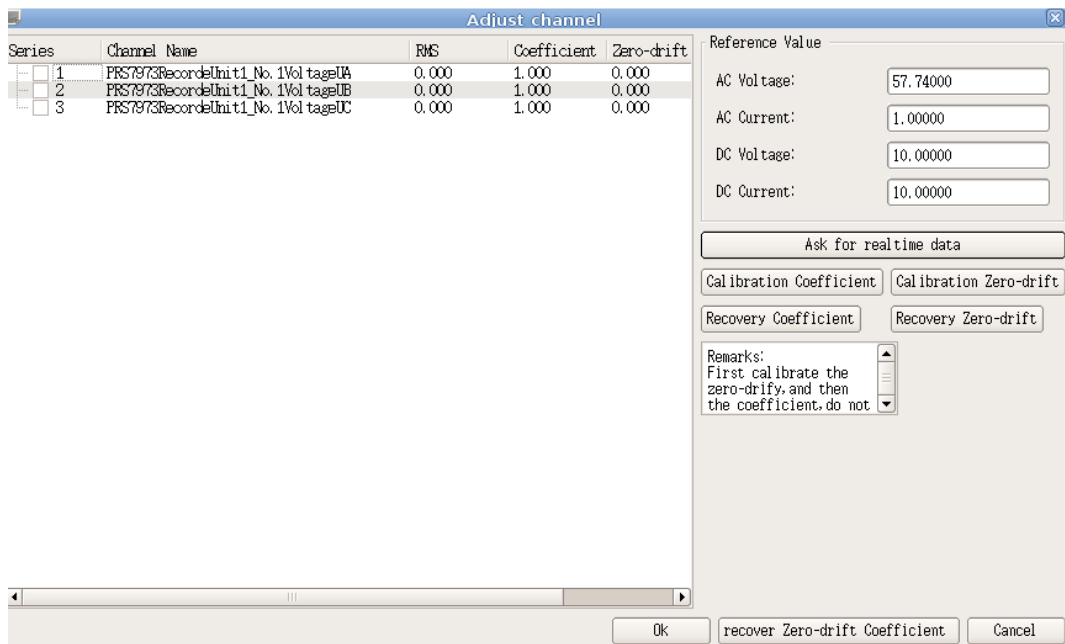
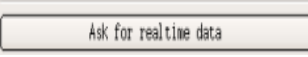

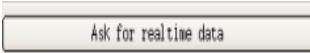



Fig.4-24

First, select the channel to be calibrated at left side. Apply value of 0 from outside.

Click button  (ask for Real-time Data) and wait for refresh of data at left side. Later, click button  (Calibration Zero Drift).

Next, in Reference Values tab (Fig.4-25), fill out ratings according to actual

conditions. Click button  and wait for refresh of data at left side. Later, click button  (Calibration Coefficient).

Finally, click button  (OK) to complete channel calibration.

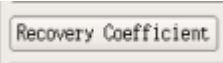
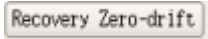
Click buttons  (Recovery Coefficient) and  (Recovery Zero Drift) to restore relevant coefficients to default values.

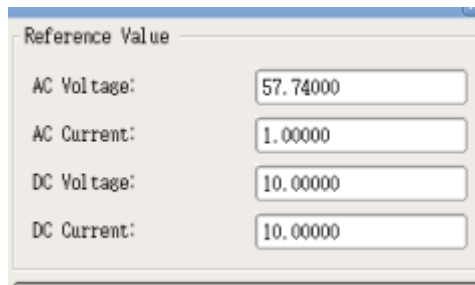
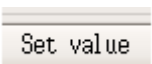

**Fig.4-25**



Attention: In case DC voltage is 10V~1000V, set DC board to 1000V gear and set DC voltage in the Reference Values tab to 100V for channel calibration.

**4.1.4 Management of settings**

In the configuration tool, click button  (Set value) to enter the Settings Management page, which includes the following tabs: global settings, AC voltage settings, AC current settings, DC voltage settings, DC current settings, voltage ordered quantity settings, current ordered quantity settings, transformer settings, generator settings, and switch enabling/disabling settings.

For global settings, refer to Table 4-1 below.

S/N	Setting name	Setting range	Default value
1	Current setting zone	1~5	1
2	Fault recording capacity	Cannot be modified	2500
3	Number of stable state files	Cannot be modified	1000
4	System frequency	50 (60)	50
5	Sampling frequency	3200~12800	12800

6	Frequency change rate		0.1
7	Calculation of 3U0/3I0		
8	Segment A fault record length	100~2000	100ms
9	Segment B fault record length	400~10000	1000ms
10	Segment C fault record length	0~20000	1000ms
11	Segment D fault record length	0~40000	1000ms
12	Segment A sampling frequency	640~12800	12800
13	Segment B sampling frequency	640~12800	12800
14	Segment C sampling frequency	640~12800	3200
15	Segment D sampling frequency	640~12800	3200

**Table 4-1**

In the AC voltage settings tab, the enabling/disabling option of each channel is the general enabling/disabling option for this channel which, if not checked, indicates that this voltage channel will not trigger start of any type of fault recording. Each such setting can be enabled/disabled separately. AC voltage settings are given in Table 4-2.

S/N	Setting name	Setting range	Default value
1	Transformation ratio		Determined by primary and secondary ratings in analog quantity configuration; no configuration required
2	Sudden variable		2.88683
3	High overreach		63.5104
4	Low overreach		51.963
5	High frequency overreach		To be modified at Global Settings; modification is not required here.
6	Low frequency overreach		To be modified at Global Settings; modification is not required here.
7	Frequency change rate		To be modified at Global Settings; modification is not required here.
8	2 <sup>nd</sup> harmonic	0~57.7	5.77367

9	3 <sup>rd</sup> harmonic	0~57.7	5.77367
10	5 <sup>th</sup> harmonic	0~57.7	5.77367
11	7 <sup>th</sup> harmonic	0~57.7	5.77367
12	9 <sup>th</sup> harmonic	0~57.7	5.77367

**Table 4-2**

AC current settings are given in Table 4-3.

S/N	Setting name	Setting range	Default value
1	Transformation ratio		Determined by primary and secondary ratings in analog quantity configuration; no configuration required
2	Sudden variable		Default: 10% rated current
3	High overreach		Default: 110% rated current
4	1500ms current variation		Default: 10% rated current

**Table 4-3**

DC voltage settings are given in Table 4-4.

S/N	Setting name	Setting range	Default value
1	Transformation ratio		Determined by primary and secondary ratings in analog quantity configuration; no configuration required
2	High DC overreach		Default: 110% rated voltage
3	Low DC overreach		Default: 80% rated voltage
4	DC sudden variable		Default: 5% rated current

**Table 4-4**

DC current settings are given in Table 4-5.

S/N	Setting name	Setting range	Default value
1	Transformation ratio		Determined by primary and secondary ratings in analog quantity configuration; no configuration required
2	High DC overreach		Default: 100% rated current



3	Low DC overreach		Default: 98% rated current
4	DC sudden variable		Default: 50% rated current

**Table 4-5**

Voltage ordered quantity settings are given in Table 4-6.

S/N	Setting name	Setting range	Default value
1	ZS sudden variable		Default: 1% rated voltage
2	ZS high overreach		Default: 1% rated voltage
3	PS high overreach		Default: 110% rated voltage
4	PS low overreach		Default: 90% rated voltage
5	NS high overreach		Default: 3% rated voltage
6	TV disconnection NS setting		Default: 1% rated voltage

**Table 4-6**

Current ordered quantity settings are given in Table 4-7.

S/N	Setting name	Setting range	Default value
1	ZS high overreach		Default: 10% rated current
2	NS high overreach		Default: 10% rated current

**Table 4-7**

Transformer settings are given in Table 4-8.

S/N	Setting name	Setting range	Default value
1	Difference current overreach (%)		Default: 100%
2	Over-excitation (%)		Default: 110%

**Table 4-8**

Generator settings are given in Table 4-9.

S/N	Setting name	Setting range	Default value
1	Reverse power (%)		Default 5%
2	Over-excitation (%)		Default: 110%

**Table 4-9**

On the switch enabling/disabling page, triggering of fault recording by each binary quantity can be enabled/disabled. Double click  Enable (Enable/disable) at upper part of the table to enable/disable all such functions.

**4.1.5 Waveform analysis**

Waveform analysis tool main interface is shown in Fig.4-26.

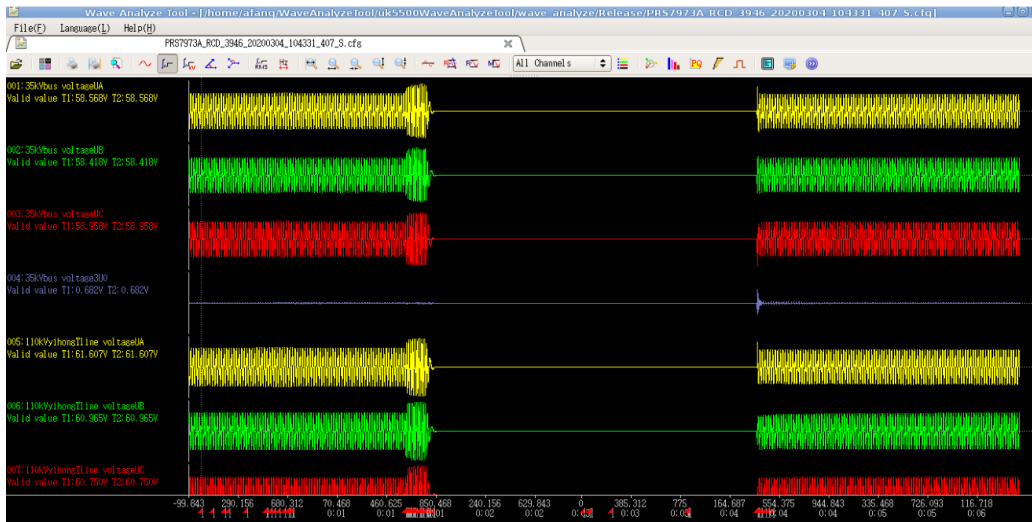

**Fig.4-26**

**4.1.5.1 Menu bar**

- File

Open: waveform file of cfg format can be opened and downloaded.

Exit: close waveform tool

- Help



























About: view software version information



**4.1.5.2 Functional bar**



The functional bar allows fast use of functions Zoom in, Zoom out, Display effective value, Display instantaneous value, Customize channel, Display fault analysis, and Brief fault report etc. for waveforms. Particular information is given in Table 4-10:

Icon	Description
	Modify tool display background color (platinum grey, classic black, sky blue, rose color)
	Print: waveforms can be printed.

	Customize waveform printing time period (T1~T2)
	Print preview: view effect of printing
	Display instantaneous value: numerical value displayed at left side
	Display effective value: numerical value displayed at left side
	Display primary effective value: numerical value displayed at left side
	Display phase angle at left side of the tool
	Display phase angle difference at left side as per customized T1 and T2
	True effective value: display whole waveform effective value at left side
	Frequency followup: display waveform frequency
	Zoom waveform to display all waveforms in one page
	Waveform transverse zoom in
	Waveform transverse zoom out
	Waveform longitudinal zoom in
	Waveform longitudinal zoom out
	Display waveform sampling points
	Use channel maximum value not less than rated value as Y axis coordinate range
	Use channel rated value as Y axis coordinate range
	Use channel maximum value as Y axis coordinate range
	Allow selection of channel display according to primary equipment configured in the configuration tool
	Allow self-defined selection of display channel
	Self-defined selection of channel for vector analysis
	Select harmonic value according to channel
	Select displayed power according to channel
	Select and analyze fault according to channel
	Change switch to list
	Full screen display of waveform analysis tool

	Screen clipping
	More: fault record HDR report, DMF file information, add time mark, add text mark, clear all time marks, clear all text marks, clear all marks, combined channel display, independent channel display, self-defined calculation channel, impedance locus, difference current analysis, over-excitation analysis, aperiodic component analysis, clip fault file

**Table 4-10**

## 5. Power Quality Monitor

### 5.1 Main function describe

Power quality monitoring module mainly includes harmonic monitoring, flicker and voltage unbalance.

#### 5.1.1 Harmonic Monitor

This such fault recorder can monitor max to 50<sup>th</sup> harmonic. Additionally, picking show monitor results with selecting how many harmonics. Now, harmonic monitor supports online and off-online to analyse data of collection.

#### 5.1.2 Flicker

There are two types of flicker, including ten-minute short flicker and two-hour long flicker. Users have optionally to choose enable or disable flicker function. It also supports graph presentation. Flicker is calculated on all three phases. Flicker data is stored in recorder memory which can be saved for more than one year.

The flicker value of half-wave effective value is calculated according to IEC flicker detection principle

#### 5.1.3 Unbalance

Voltage unbalance is a condition in which the RMS values of the phase voltages or the phase angles between consecutive phases are not equal. The level of unbalance is typically monitored from 10-minute average intervals and is expressed in %. The recorder device can set a programmed value for the unbalance voltage of each phase

## 6. Commissioning

### 6.1 General

This equipment has continuous comprehensive self-check function and will generate alarm information upon any equipment fault or operation abnormality.

 Attention:

Before any operation of this equipment, user shall be familiar with safety descriptions, contents of the chapter of technical parameters, and rated parameters marked on equipment nameplate.

## 6.2 Safety description



Warning:

Operating electrical equipment has dangerous voltage and violation of safety rules may cause serious personnel injury or equipment damage.



Warning:

Only qualified professionals are allowed to operate this equipment or work near this equipment. Working personnel shall be familiar with precautions, work flows, and safety rules mentioned in this manual.

Pay special attention to the following issues:

- Before other electrical wiring, ensure reliable connection of equipment earthing rod to protection earth;
- During commissioning, applied quantities must be within the ranges specified by Table of Technical Parameters in Chapter 2, which shall never be exceeded.

## 6.3 Inspection of equipment

Equipment inspection shall include all aspects and ensure no visible damage before this equipment is put into operation, as well as normal operation.

### 6.3.1 Inspection power-on

The following test items must be carried out to ensure normal operation before this equipment is put into operation for the first time.

#### 6.3.1.1 Visual inspection

After unpacking this product, check equipment chassis for damage. Such damage (if any) will possibly affect internal cards; please contact manufacturer or its agent. Inspection items are as follows:

- Inspection of panel/cabinet

Carefully check the panel/cabinet, this equipment, and other components to ensure no visible damage. Check rated parameters of related other equipment or relay for matching.

- Wiring of panel/cabinet

Carefully check wiring in the panel/cabinet to ensure conductor cross sectional area meeting requirements and correct connection.

- Labels

Check labels of all linking pieces, terminal blocks, indicators, change-over switches, and buttons to ensure satisfaction of engineering requirements.

- Equipment cards that can be plugged and unplugged

Check each such card to ensure that it can be plugged home without loose screw

- Earthing wire

Check earthing wires of panel/cabinet terminal blocks for safe and reliable connection to panel/cabinet earthing copper bar using screws.

- Change-over switches, keyboard, linking pieces, buttons

Carefully check all change-over switches, keyboard, linking pieces, and buttons to ensure their normal operation and smooth use.

**6.3.1.2 Check of external wiring**

Check equipment external wiring for consistency with equipment wiring diagram and engineering design drawings, while ensuring actual phase sequence of wiring same as designed phase sequence.

According to installation schematic drawings, check wiring to ensure consistency with actual user application.

**6.3.1.3 Check DC power supply**

This equipment can run normally with 110V or 220V DC power supply. The DC power supply voltage depends on equipment power supply rated parameters. To ensure normal operation of this equipment, input power supply voltage must be in the range specified in the table below. Before power-on of this equipment, make sure to measure DC power supply voltage to ensure it within specified working voltage range.

Rated voltage (Un)	DC 110V, DC220V
Input range	(80% ~ 120%)Un

It shall be emphasized that this equipment can withstand maximum ripple of 15% DC rated value.



For power-on of this equipment, ensure DC power supply voltage in specified working voltage range.

## **7. Maintenance**

### **7.1 Arrangement of maintenance schedule**

After installation of this equipment, periodic inspection and maintenance is recommended. If this equipment runs in severe natural conditions and seldom operates, it shall be confirmed in normal running state or not at certain interval.

This equipment has complete self-check function. Most problems found by self-check will trigger equipment alarm, to prompt user to timely take remedy measures. Only a few hardware faults will block this equipment. However, periodic inspection and testing is required to ensure that all functions of this equipment are normal and all external wiring is intact.

### **7.2 Tracking of faults and repair**

In case of fault found by equipment self-check, an alarm signal will be generated. Self-check message will be displayed on the LCD panel, with relevant alarm indicator lit.

In case of fault found by conventional inspection, confirm the following one by one:

- Check or test for correct circuit connections
- Check for correct position and full insertion of cards
- Check for correct DC power supply voltage level

### **7.3 Replacement of faulty card**

In case a fault is confirmed in a card and spare part of this card is available, user can replace this card to restore equipment operation.

Site maintenance of this equipment is limited to card replacement. Component level maintenance is not recommended on site.

Check to ensure that name and hardware model of replacement card identical to those of the replaced card. Besides, for replacement of CPU or time service card, ensure the same software version of the replacement card and the replaced card. For replacement of DC power supply card, ensure the same rated parameters of the replacement card and the replaced card.



Warning:

Card or device can only be replaced after cutoff of equipment power supply and by trained and qualified personnel. Also, strict antistatic measures shall be taken to provide protection against static electricity.



Warning:

For operation of a card, antistatic measures shall be taken, e.g. wearing antistatic cuff and placing the card on earthed conducting pad etc.; otherwise electronic device in the card may be damaged. After replacement of CPU card, check the settings.



Danger:

After replacement of a card, it is necessary to check and ensure identical equipment configuration and external wiring before and after card replacement.

#### **7.4 Cleaning**

Before cleaning this equipment, ensure disconnection of DC power supply to prevent electric shock during cleaning.

Smooth cloth and clear water are recommended for cleaning of this equipment. Do not use abrasive or cleaning agent.

#### **7.5 Storage**

Spare equipment and cards shall be stored in a clean and dry room. IEC60255-6 standard specifies storage temperature range of  $-40^{\circ}\text{C}\sim 70^{\circ}\text{C}$  and recommends long-term storage temperature range of  $-10^{\circ}\text{C}\sim 40^{\circ}\text{C}$ .